



*Most Widely Accepted and Trusted*

# ICC-ES Evaluation Report

## ESR-4293

Issued 12/2018

ICC-ES | (800) 423-6587 | (562) 699-0543 | [www.icc-es.org](http://www.icc-es.org)

This report is subject to renewal 12/2019.

**DIVISION: 31 00 00—EARTHWORK**

**SECTION: 31 60 00—SPECIAL FOUNDATIONS AND LOAD-BEARING ELEMENTS**

**REPORT HOLDER:**

**SOUND FOOTINGS LLC**

**EVALUATION SUBJECT:**

**SOUND FOOTINGS LLC TUBEBASE® AND SQUARE FOOT® FOOTING FORMS**



*“2014 Recipient of Prestigious Western States Seismic Policy Council (WSSPC) Award in Excellence”*



*ICC-ES Evaluation Reports are not to be construed as representing aesthetics or any other attributes not specifically addressed, nor are they to be construed as an endorsement of the subject of the report or a recommendation for its use. There is no warranty by ICC Evaluation Service, LLC, express or implied, as to any finding or other matter in this report, or as to any product covered by the report.*



# ICC-ES Evaluation Report

**ESR-4293**

Issued December 2018

This report is subject to renewal December 2019.

[www.icc-es.org](http://www.icc-es.org) | (800) 423-6587 | (562) 699-0543

A Subsidiary of the International Code Council®

**DIVISION: 31 00 00—EARTHWORK**  
**Section: 31 60 00—Special Foundations and Load-bearing Elements**

**REPORT HOLDER:**

**SOUND FOOTINGS LLC**

**EVALUATION SUBJECT:**

**SOUND FOOTINGS LLC TUBEBase® AND SQUARE FOOT® FOOTING FORMS**

## 1.0 EVALUATION SCOPE

**Compliance with the following codes:**

- 2018 and 2015 *International Building Code*® (IBC)
- 2018 and 2015 *International Residential Code*® (IRC)

**Property evaluated:**

Structural

## 2.0 USES

The Sound Footings LLC TubeBase® and Square Foot® footing forms are stay-in-place formwork for concrete spread foundations and footings used with fiber construction tubes to form concrete piers. The TubeBase® and Square Foot® Footing Forms are identical except for the name.

## 3.0 DESCRIPTION

### 3.1 General:

The TubeBase® and Square Foot® footing forms are square-shaped plastic formwork available in three sizes. The 22-inch size is designated as TB 22 or SF 22; the 28-inch size is designated as TB 28 or SF 28; and the 32-inch size is designated as TB 32 or SF 32. The forms are intended for concrete footing widths of 22 inches, 28 inches and 32 inches (559 mm, 711 mm and 813 mm), respectively. The footing forms are designed with removable stepped sections at the top to accept different diameters of fiber construction tubes. The bottoms of the footing forms have a flange designed to fit flat on the excavated area. The footing forms are manufactured from Prime Block CoPolymer Polypropylene. See Table 1 and Figure 1 for product dimensions and details.

### 3.2 TB 22 TubeBase® and SF 22 Square Foot® Footing Forms:

The TB 22 or SF 22 footing forms are 22 inches (559 mm) square and 16.6 inches (422 mm) high, and have a

nominal wall thickness of 0.10 inch (2.54 mm). The TB 22 and SF 22 have twenty, 1/4-inch-diameter (6.35 mm) holes to permit trapped air to escape. The TB 22 and SF 22 have six rings on the top of the footing form to attach nominally 8- or 10-inch-diameter (203 or 254 mm) fiber construction tubes. The diameter and height of the rings are noted in Table 1 and Figure 1.

### 3.3 TB 28 TubeBase® and SF 28 Square Foot® Footing Forms:

The TB 28 and SF 28 footing forms are 28 inches (711 mm) square and 20 inches (508 mm) high, and have a nominal wall thickness of 0.10 inch (2.54 mm). The TB 28 and SF 28 have twenty-four, 5/16-inch-diameter (7.9 mm) holes to permit trapped air to escape. The TB 28 and SF 28 have nine rings on the top of the footing form to attach nominally 8-, 10- or 12-inch-diameter (203, 254 or 305 mm) fiber construction tubes. The diameter and height of the rings are noted in Table 1 and Figure 1.

### 3.4 TB 32 TubeBase® and SF 32 Square Foot® Footing Forms:

The TB 32 and SF 32 footing forms are 32 inches (813 mm) square and 22 inches (560 mm) high, and have a nominal wall thickness of 0.10 inch (2.54 mm). The TB 32 and SF 32 have twenty, 3/8-inch-diameter (9.5 mm) holes to permit trapped air to escape. The TB 32 and SF 32 have six rings on the top of the footing form to attach nominally 12-, 14-, 16- or 18-inch-diameter (305, 356, 406 or 457 mm) fiber construction tubes. The diameter and height of the rings are noted in Table 1 and Figure 1.

### 3.5 Fiber Construction Tubes:

The fiber construction tubes must be cellulosic fiber tubes having a minimum wall thickness of 0.080 inch (2.0 mm). The fiber construction tubes are supplied by others, as recommended by Sound Footings LLC. See Table 2 for recommended construction tubes. See Table 3 for fiber construction tube diameters.

### 3.6 Concrete:

Normal-weight concrete, complying with the applicable code and using 3/4-inch (19 mm) maximum size aggregate and a 5-inch (127 mm) slump, must be used.

## 4.0 DESIGN AND INSTALLATION

### 4.1 Design:

The concrete footing systems described in this report must be designed in accordance with the IBC. For installation under the IRC, design must be in accordance with Chapter 4 of the IRC and applicable portions of the IBC.

Lateral load resistance and skin friction resistance is beyond the scope of this report.

The bearing and uplift loads applied to the footing are determined in accordance with the applicable code. The uplift capacity is the weight of the concrete in the construction tube and footing form.

The connection between the concrete pier and the structure are outside the scope of this report. The connection must be designed for all loads as determined in accordance with the applicable code.

## 4.2 Installation:

**4.2.1 General:** Rings on the top of the footing form that are smaller than the largest diameter ring fitting inside the construction tube being used must be cut and removed from the footing form. The fiber construction tube must be installed over the appropriately sized ring of the footing form, and must be attached to the form using a minimum of four  $\frac{3}{4}$ - to 1-inch-long (19 to 25 mm), No. 8, sheet metal screws.

The footing forms must be placed on undisturbed soil or compacted fill in accordance with Section 1803 of the IBC, and Section R403 of the IRC. The bottom of the forms must be installed below the frost line in accordance with the applicable code. Backfill must be placed over the footing form to a depth of 5 feet (1524 mm) from the bottom of the footing form and compacted, prior to concrete placement. Any additional backfilling must be completed after the concrete has been placed. Concrete must be placed in accordance with the applicable code. In addition, the concrete must be placed in lifts of 10 to 16 inches (254 to 406 mm), with the concrete being consolidated after each lift.

For installations where the fiber construction tube extends 3 feet (914 mm) or more above ground level, the top of the fiber construction tube must be braced as shown in Figure 2 of this report, with four scab boards attached to the construction tube by two or more screws per board, installed from inside the fiber construction tube.

After the concrete has cured, the braces must be removed, and the upper end of the fiber construction tube must be removed to a depth of 12 inches (305 mm) below the finished grade. The remainder of the fiber construction tube, and the plastic footing form, are permitted to remain in place.

**4.2.2 TB 22 or SF 22 Installation:** The length of the 8-inch-diameter (203 mm) fiber construction tube on the TB 22 or SF 22 footing forms must be such that the combined height of the footing form and the fiber construction tube does not exceed 8 feet (2438 mm), with a maximum aboveground concrete height of 3 feet (914 mm). The length of the 10-inch-diameter (254 mm) fiber construction tube on the TB 22 or SF 22 footing form must be such that the combined height of the footing form and the fiber construction tube does not exceed 13 feet (3962 mm), with a maximum aboveground concrete height of 8 feet (2438 mm).

**4.2.3 TB 28 or SF 28 Installation:** The length of the 8-inch-diameter (203 mm) fiber construction tube on the TB 28 or SF 28 footing forms must be such that the combined height of the footing form and the fiber

construction tube does not exceed 8 feet (2438 mm), with a maximum aboveground concrete height of 3 feet (914 mm). The length of the 10- or 12-inch-diameter (254 or 305 mm) fiber construction tubes on the TB 28 or SF 28 footing forms must be such that the combined height of the footing form and the fiber construction tube does not exceed 13 feet (3962 mm), with a maximum aboveground concrete height of 8 feet (2438 mm).

**4.2.4 TB 32 or SF 32 Installation:** The length of the 12-, 14-, 16-, and 18-inch-diameter (305, 356, 406, and 457 mm) fiber construction tubes on the TB 32 or SF 32 footing forms must be such that the combined height of the footing form and the fiber construction tube does not exceed 13 feet (3962 mm), with a maximum aboveground concrete height of 8 feet (2438 mm).

## 5.0 CONDITIONS OF USE

The Sound Footings LLC TubeBase<sup>®</sup> and Square Foot<sup>®</sup> footing forms described in this report comply with, or are suitable alternatives to what is specified in, those codes listed in Section 1.0 of this report, subject to the following conditions:

- 5.1 The footing form system is installed in accordance with this evaluation report and the manufacturer's published installation instructions. The instructions in this report must govern if there are any conflicts between the manufacturer's instructions and this report.
- 5.2 The concrete footing systems described in this report must be designed in accordance with Section 4.1 and the applicable codes.
- 5.3 When required by the code official, engineering calculations and drawings must be submitted when a permit is applied for. The calculations and drawings must be signed, sealed, and dated by a registered design professional, when required by the statutes of the local jurisdiction.
- 5.4 Special inspection must be provided in accordance with IBC Section 1704, as applicable.

## 6.0 EVIDENCE SUBMITTED

Data in accordance with the ICC-ES Acceptance Criteria for Plastic Footing Form Systems (AC292), dated February 2005 (editorially revised June 2018).

## 7.0 IDENTIFICATION

- 7.1 The Sound Footings LLC TubeBase<sup>®</sup> and Square Foot<sup>®</sup> footing forms are engraved with the model number on the base, and have labels noting the name of the evaluation report holder (Sound Footings LLC) and the ICC-ES evaluation report number (ESR-4293).
- 7.2 The report holder's contact information is the following:

**SOUND FOOTINGS LLC**  
277 BLAIR PARK ROAD, SUITE 120  
WILLISTON, VERMONT 05495  
(802) 764-2323  
[www.soundfootings.com](http://www.soundfootings.com)

**TABLE 1—TUBE RING DIAMETER AND HEIGHT**

RING DIAMETER	TB 22/SF 22 (inches)	TB 28/SF 28 (inches)	TB 32/SF 32 (inches)
D1	7.53	7.53	11.50
D2	8.03	8.03	12.00
D3	8.45	8.45	12.45
D4	9.48	9.48	14.10
D5	9.90	9.90	16.10
D6	10.40	10.40	18.10
D8	—	11.50	—
D9	—	12.00	—
D10	—	12.45	—
D7	23.50	30.00	34.50
D0	22.00	28.00	32.00
RING HEIGHT	TB 22	TB 28	TB 32
H1	16.60	20.00	22.10
H2	15.43	19.00	20.85
H3	14.01	18.00	19.60
H4	12.85	17.00	18.35
H5	11.68	16.00	16.60
H6	10.26	15.00	14.60
H7	—	14.00	—
H8	—	13.00	—
H9	—	12.00	—

**TABLE 2—SOUND FOOTINGS, LLC RECOMMENDED CONSTRUCTION TUBES**

CONSTRUCTION TUBE COMPANY	CONSTRUCTION TUBE NAME
Sonoco	Builders Tube; Sonotube®
King Packaged Materials Company, Sonoco, Canada	King Builders Tube, Light Wall
Sonoco USA	Builders Tube, Light Wall; Sonotube®
EasternTube/Division of Abzac Canada Inc.	Eastern Tube
Mayers Fibre Tube & Core	Easy Pour; Light Wall
Crown Fibre Tube, Inc.	Econo and Premium Fibre Forms
Caraustar Industrial and Consumer Products Group	Kolumn Form
Newark Paper Board Products	New Form (Standard/Heavy); Quickrete Tubes

**TABLE 3—DIAMETERS OF CONSTRUCTION TUBES AND SOUND FOOTINGS LLC TUBEBASE® AND SQUAREFOOT® FORM**

Nominal Diameter (inches)	CONSTRUCTION TUBE		SOUND FOOTINGS LLC TUBEBASE® AND SQUAREFOOT® FORM RING SIZE DIAMETER (inches)
	Size	Inside Diameter (inches)	
8	Small	7.53	7.53
	Medium	8.03	8.03
	Large	8.45	8.45
10	Small	9.46	9.46
	Medium	9.90	9.90
	Large	10.40	10.40
12	Small	11.50	11.50
	Medium	12.00	12.00
	Large	12.45	12.45
14	Medium	14.10	14.10
16	Medium	16.10	16.10
18	Medium	18.10	18.10

For SI: 1 inch = 25.4 mm.

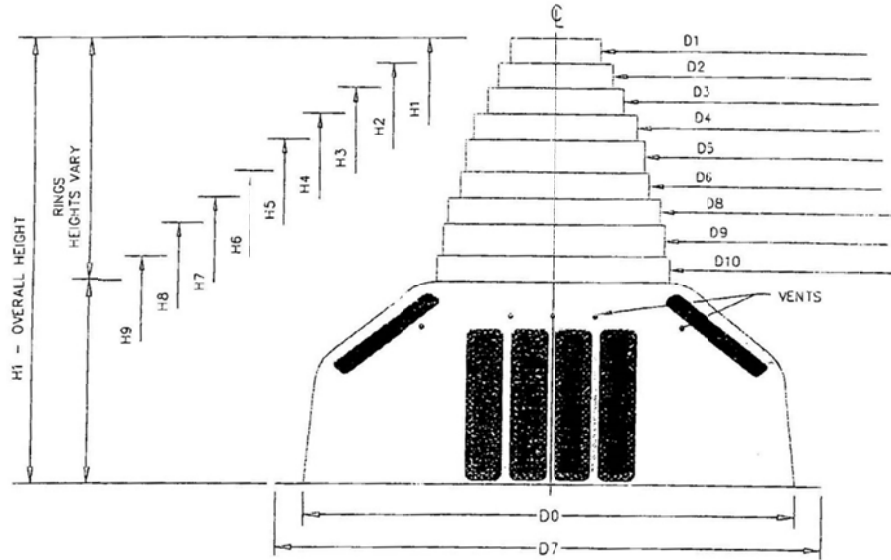

FIGURE 1—TUBE BASED AND SQUARE FOOT FOOTING FORMS

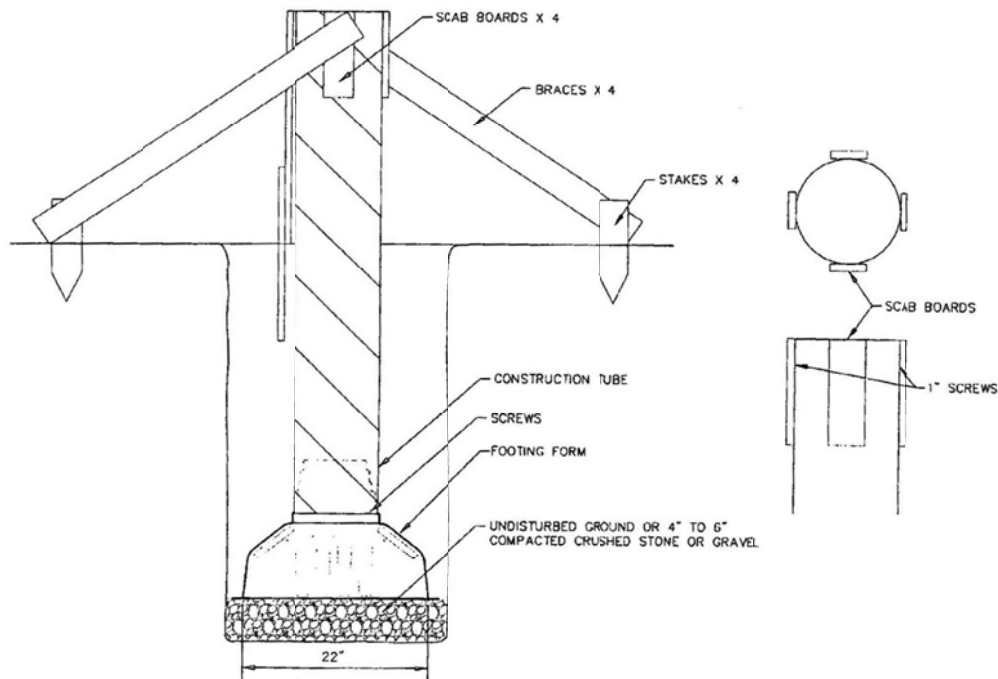

FIGURE 2—TYPICAL INSTALLATION